



Extension Extra

ExEx 1001
Updated April 2002
Agriculture and
Biosystems
Engineering

COLLEGE OF AGRICULTURE & BIOLOGICAL SCIENCES / SOUTH DAKOTA STATE UNIVERSITY / USDA

Don't Lose Scarce & Expensive Hay Through Storage or Feeding

*Bob Durland & Steve Pohl
Extension Agricultural Engineers*

Does it make sense to invest the time, labor and equipment in harvesting hay and then lose 30% of it during storage? With a 1150 # round bale, worth \$65/ton, this would amount to a loss of 345 # of hay, valued at \$11.21, per bale. A producer who feeds his own hay is not only out the value of the damaged hay, but may have to purchase additional feed to replace that lost, doubling his expense.

We could rationalize and say that we don't have to worry about storage losses under dry conditions, because it is too dry. However, there are no guarantees when it comes to weather; substantial amounts of rain and snow could still damage the hay. The only guarantee we have is the amount of hay harvested and stored. We should then insure that we are going to save as much of this as possible by utilizing good storage and filling methods.

Losses in quality are affected by several factors in outside storage of bales. Hay exposed to the elements can spoil and become unpalatable to livestock, nutrients are leached out by precipitation and leave less digestible dry matter, and precipitation and soil moisture can penetrate the hay mass, providing a moist environment for fungi and bacteria.

Another rationalization for poor hay storage is that the spoilage on a big bale "is only 4" or 6" deep". On a 5 1/2 ft. diameter bale weighing 1150 pounds, 4" of spoilage around the outside of the bale amounts to 23% of the bale or 265 lbs of hay. Spoilage 6" deep amounts to 33% of the bale or 380 lbs of hay. At a cost of \$65/ton, this amounts to a loss of \$8.60 and \$12.35 per bale, respectively.

Hay stored outside should be stored on a well drained site. Research has shown that stacked bales outside, usually have the largest losses, 30% to 50% in many cases. Providing a storage base of crushed rock, railroad ties, or posts will help protect these bales from spoilage caused by soil moisture. The best outside storage method is to locate the packages in a well drained area in a row parallel to prevailing winds, with a 12" to 18" space between each package. This allows the air to circulate around the bales to keep them dry (Figure A). If plastic bale

covers or bags are used, they should be fastened securely to the bale so the wind will not tear them. The covers will cost about \$3 plus per bale while the bags will cost about \$8 per bale. The best protection to preserve hay quality is a permanent hay shed. Storage losses in a shed can be kept at 2% to 3%. This reduction in losses can save enough to pay for a shed in 7 to 8 years in addition to providing quality forage (Table I).

Waste from self-feeding can be as high as 50%. Trampling creates mud and usually kills vegetation when stacks are self fed in the hay field. Hay waste can be reduced to 5%-10% by controlling animal access to the hay. Several methods to regulate animal access are as follows:

- Storage with fence on 3 sides; use electric fence along the fourth side to control access and hay consumption, Fig. 1. Allow 4"-6" of space/head when hay is always available and 18"-24"/head for limited feeding.
- Place large bales and stacks in lines 15' apart and 8'-10' from a permanent fence. Move temporary fencing to expose one bale or stack at a time.
- Self-feed whole bales or stacks in 3-sided fence line feeders or a push-up feeding fence, Fig. 2.
- Self-feed whole bales or stacks in circular feeders, feeder panels, or portable feeders, Fig. 4.
- Limit feed to day's supply with a bale unroller or a feeder attachment on a trailed stack mover. Drop the hay on the ground or into bunks, Figs. 3 and 4.

Storing forages in a hay shed combined with a controlled feeding method can reduce hay losses, in the storage and feeding process, by as much as 75%. Using our previous example, of an 1150 # bale and hay priced at \$65, this loss amounts to \$28 per bale or an equivalent of about \$49/ton. This is income lost that could be prevented by good hay management.

Table 1. Value of Hay Lost in Storage.

| Storage Loss $\frac{1}{2}$ / % | Dollar Value of Loss When Hay Price Per Ton Is: | | | | |
|-----------------------------------|---|----------------|----------------|----------------|-----------------|
| | \$20 (\$/T) | \$40 (\$/T) | \$60 (\$/T) | \$80 (\$/T) | \$100 (\$/T) |
| 5 | 1.00 | 2.00 | 3.00 | 4.00 | 5.00 |
| 10 | 2.00 | 4.00 | 6.00 | 8.00 | 10.00 |
| 15 | 3.00 | 6.00 | 9.00 | 12.00 | 15.00 |
| 20 | 4.00 | 8.00 | 12.00 | 16.00 | 20.00 |
| 25 | 5.00 | 10.00 | 15.00 | 20.00 | 25.00 |
| 30 | 6.00 | 12.00 | 18.00 | 24.00 | 30.00 |
| 35 | 7.00 | 14.00 | 21.00 | 28.00 | 35.00 |
| 40 | 8.00 | 16.00 | 24.00 | 32.00 | 40.00 |

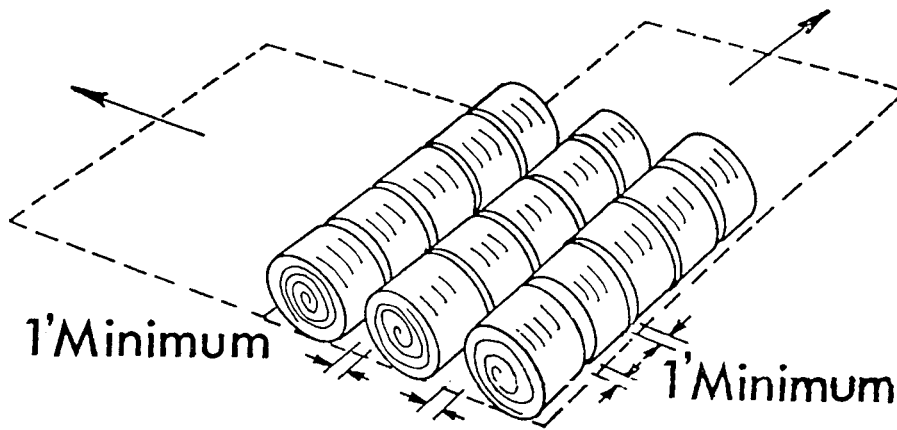

(a) Bales stored on roll-side.

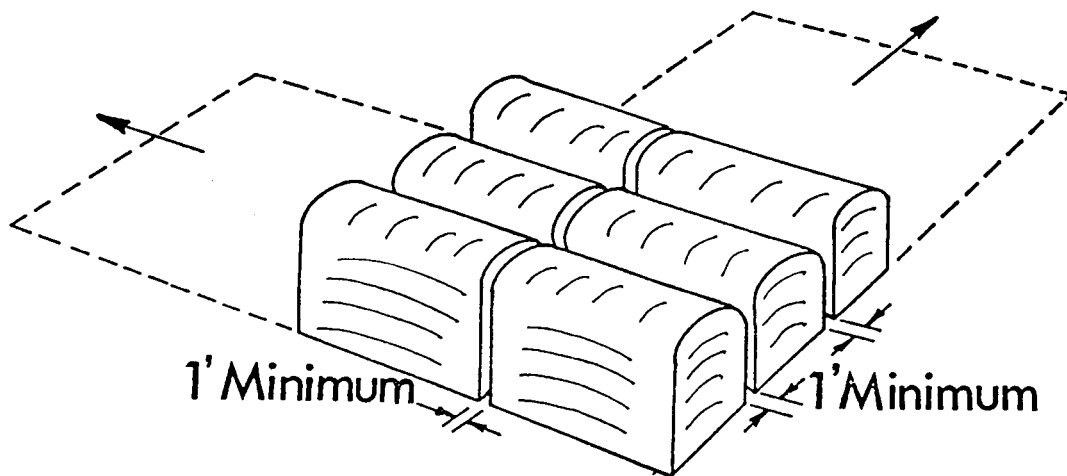

(b) Large stacks.

Figure A. Storage arrangements when big hay packages are stored outside, unprotected.

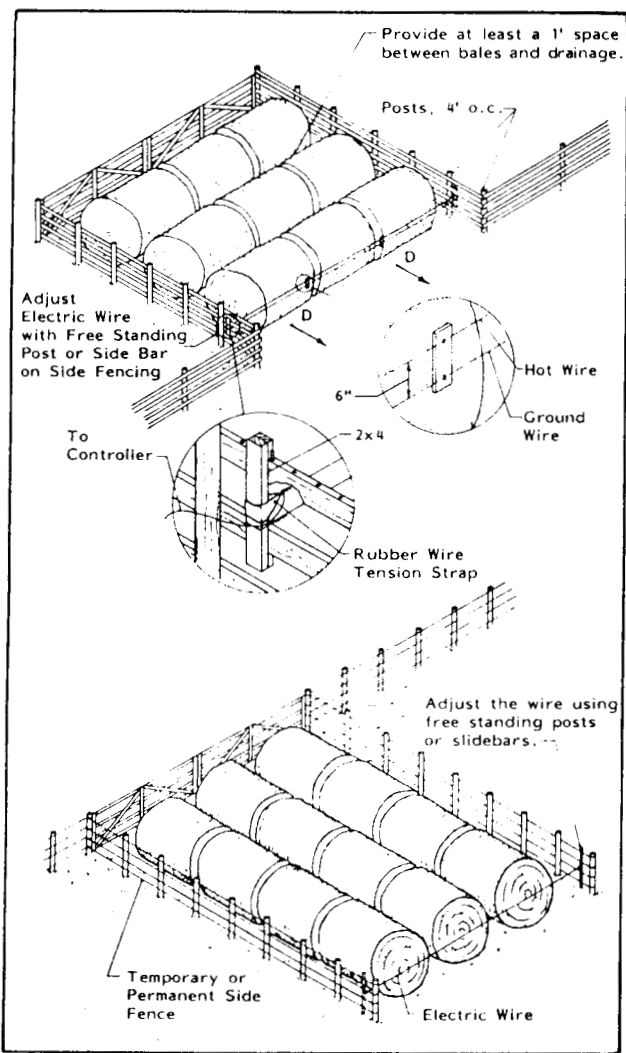

Fig 1. Rationing hay with a 2-wire electric fence.
Animals feed under the hot wire, which is moved as required to control consumption. Slope away from the electric feeding fence to promote drainage. Provide drainage between and under bales if stored at the site for several months.

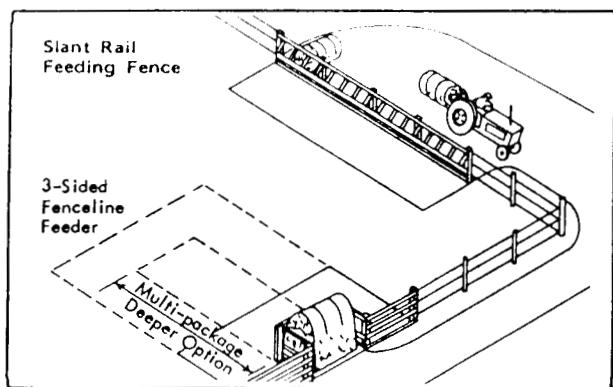

Fig 2. Fenceline feeding of big bales and stacks.
Push the hay closer, as necessary. Clean manure away weekly. Frozen buildup can cause problems.

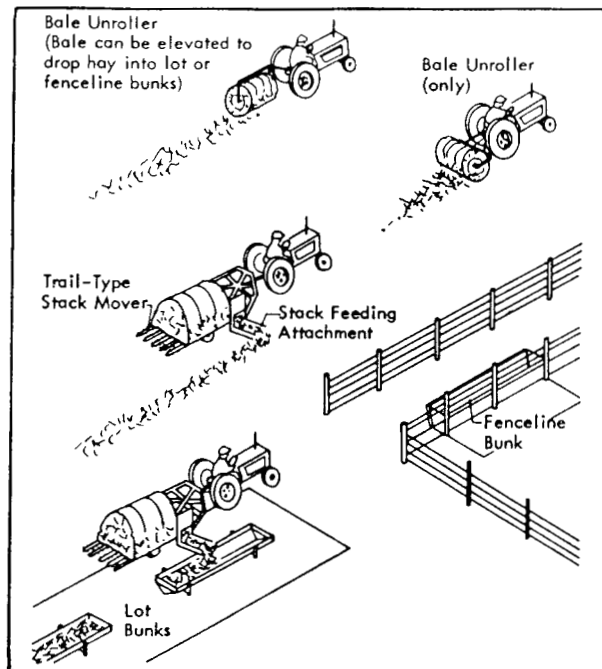

Fig 3. Big bale and stack limit feeding methods.
Feed on clean ground or in fenceline bunks.

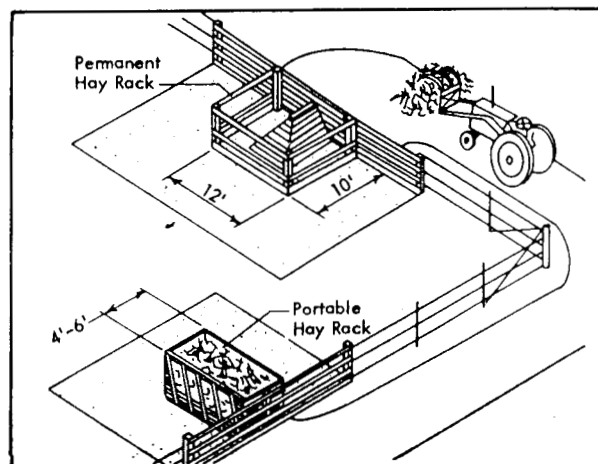

Fig 4. Limit feeding roughage.
Fill feeders with a front-end loader or by hand for a small operation.

Issued in furtherance of Cooperative Extension work, Acts of May 8 and June 30, 1914, in cooperation with the USDA. Richard A. Battaglia, Director of CES, SDSU, Brookings. Educational programs and materials offered without regard to age, race, color, religion, sex, handicap, or national origin. An Equal Opportunity Employer.

This publication and others can be accessed electronically from the SDSU College of Agriculture & Biological Sciences publications page, which is at <http://agbiopubs.sdstate.edu/articles/ExEx1001.pdf>



Issued in furtherance of Cooperative Extension work, Acts of May 8 and June 30, 1914, in cooperation with the USDA. Larry Tidemann, Director of Extension, Associate Dean, College of Agriculture & Biological Sciences, South Dakota State University, Brookings. SDSU is an Affirmative Action/Equal Opportunity Employer (Male/Female) and offers all benefits, services, and educational and employment opportunities without regard to ancestry, age, race, citizenship, color, creed, religion, gender, disability, national origin, sexual preference, or Vietnam Era veteran status.

ExEx 1001 - pdf by CES. August 1988; updated April 2002.