

Sandbagging for Flood Protection

A properly built sandbag dike can prevent or reduce flood damage.

Bags must be filled and placed properly to give the best protection. Any available material can be used to fill sandbags, but sand is easiest to handle. Silt and clay will form a good dike but are more difficult to work with. Different size bags are available, but bags are easier to handle if weight is limited to less than 35 pounds. This is particularly important when teenagers or older persons will be handling the bags.

A rack such as the one in Figure 1 can be constructed to hold bags open for filling. Such a rack is easily moved and the bags can be filled with a ready-mix concrete truck, front end loader, or an elevator with a bag-filling spout. As the bags are filled the rack can be moved to minimize handling filled bags.

Fill sandbags approximately half full. Do not tie.

The number of bags needed for 100 linear feet of dike is:

- 800 bags for 1-foot-high dike
- 2,000 bags for 2-foot-high dike
- 3,400 bags for 3-foot-high dike

Contact your county emergency office for information on where to obtain sandbags.

Site Selection

Select the location for the dike taking advantage of natural land features that keep the dike as short and low as possible. Avoid any obstructions which would weaken the dike. Do not build the dike against a building wall. Leave about 8 feet to maneuver between the dike and buildings.

Remove all ice and snow from a strip of land at least as wide as the base of the dike. If the dike is to be more than about 3 feet high, remove a strip of sod to provide better anchorage for the dike.

Stacking Sandbags

Overlap the sandbags as shown in Figure 2, placing the first layer of bags lengthwise of the dike and lapping the bags so the filled portion of one bag lies on the unfilled portion of the next. The base of the dike should be three times as wide as the dike is high, as shown in Figure 3. The second layer of bags should be perpendicular to the first layer, then alternate direction of the bags to the top of the dike.

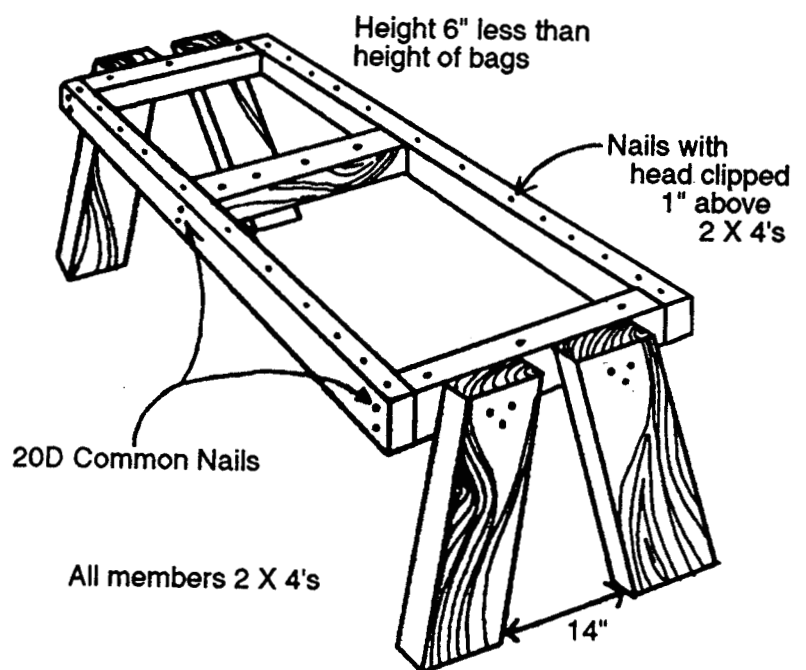

Figure 1. Rack for filling sandbags.

Sealing the Dike

The finished dike can be sealed with a sheet of plastic to improve water tightness. Spread a layer of dirt or sand 1 inch deep and about 1 foot wide along the bottom of the dike on the water side. Lay polyethylene plastic sheeting so the bottom extends 1 foot beyond the bottom edge of the dike over the loose dirt. The upper edge should extend over the top of the dike. The sheeting should be about 6 mils thick. It is generally available in 100-foot rolls from construction supply firms, lumberyards and farm stores.

Lay the plastic sheeting down very loosely. The pressure of the water will then make the plastic conform easily with the sandbag surface. If the plastic is stretched too tightly the water force could puncture it.

Place a row of sandbags on the bottom edge of the plastic to form a water-tight seal along the water side.

Place sandbags at about 6-foot intervals to hold down the top edge of the plastic. Place boards or dirt between the bags to prevent winds from disturbing the plastic. Avoid puncturing the plastic with sharp objects or by walking on it.

For additional information about preparing for a flood, cleanup and recovery after a flood, contact your county Extension office.

Stacking Sandbags

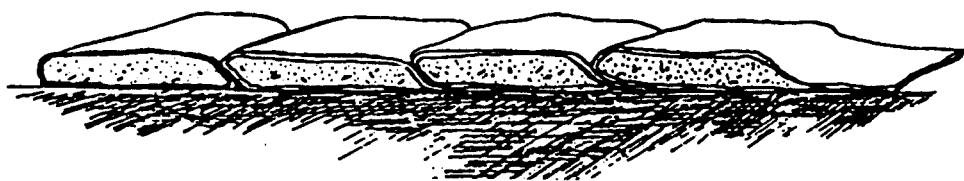

Figure 2. Overlapping sandbags.

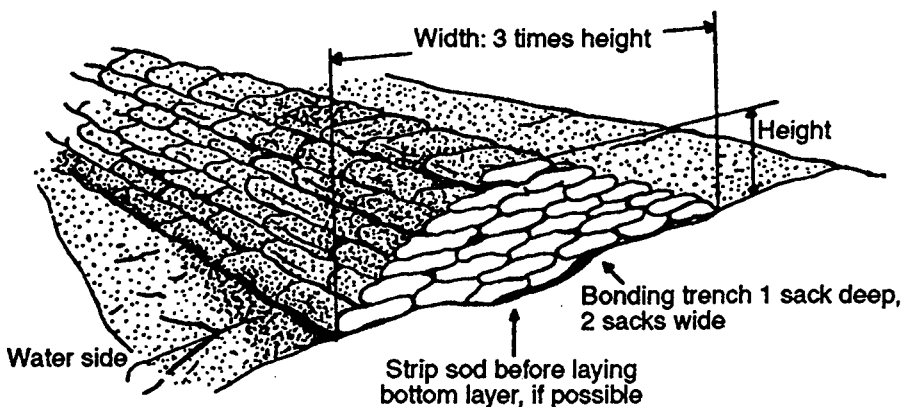

Figure 3. Stacking sandbags.

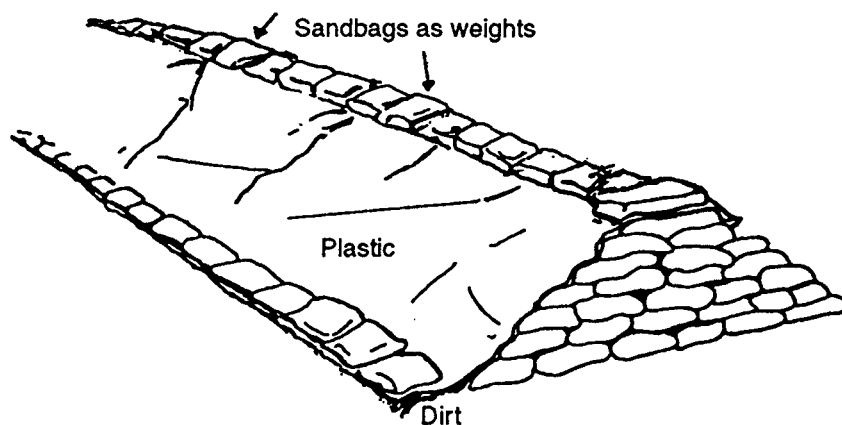

Figure 4. Sealing the sandbag dike.

This publication and others can be accessed electronically from the SDSU College of Agriculture & Biological Sciences publications page, which is at <http://agbiopubs.sdstate.edu/articles/ExEx1036.pdf>



Issued in furtherance of Cooperative Extension work, Acts of May 8 and June 30, 1914, in cooperation with the USDA. Larry Tidemann, Director of Extension, Associate Dean, College of Agriculture & Biological Sciences, South Dakota State University, Brookings. SDSU is an Affirmative Action/Equal Opportunity Employer (Male/Female) and offers all benefits, services, and educational and employment opportunities without regard for ancestry, age, race, citizenship, color, creed, religion, gender, disability, national origin, sexual preference, or Vietnam Era veteran status.

ExEx 1036- pdf by CES. March 1997; updated April 2002.